

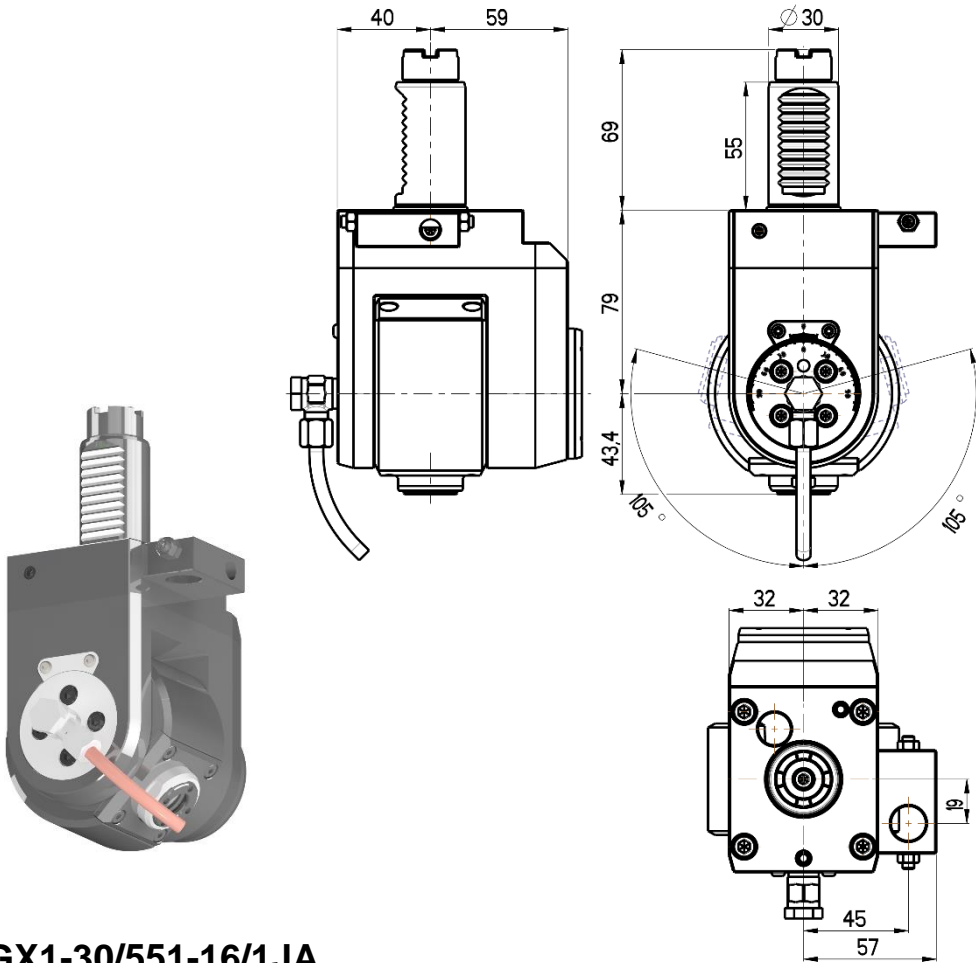

VARIABLE ANGLE LIVE TOOL HOLDER VDI 30 / STEPPED



RGX1-30/551-16/1JA

Max. speed: 6000 rpm

Max. torque: 16 Nm

Collet: ER16

Direction of rotation:

Ratio: 1:1

Cooling: external (internal cooling available)

Accessories

Nut: Caliper pin wrench

Spindle: Spanner 28