

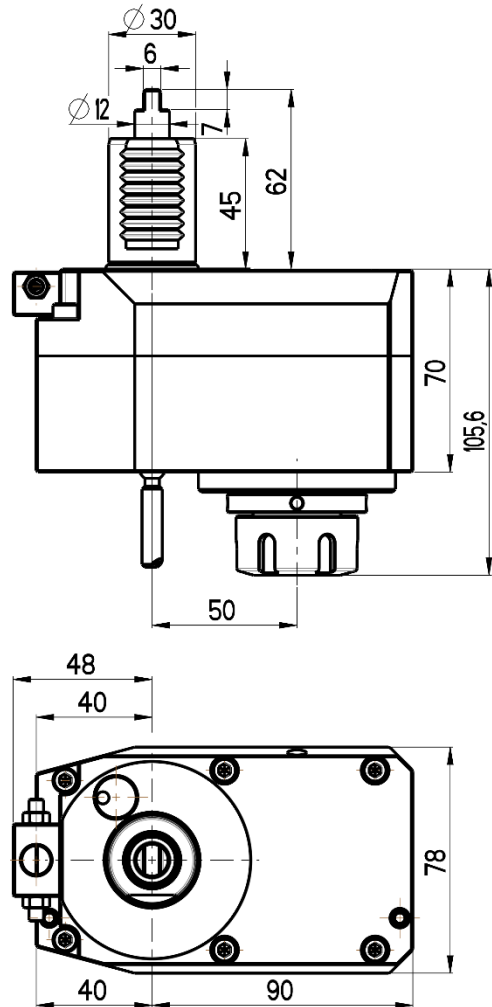

OFFSET STRAIGHT LIVE TOOL HOLDER

VDI 30 / DIN 1809

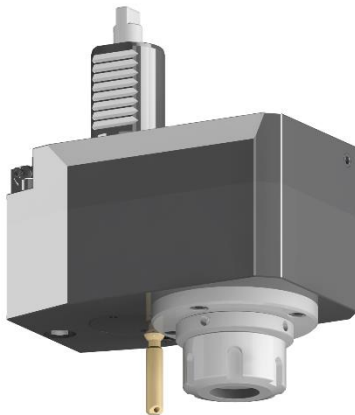

RGX1-30/321-25/1.1-50(1:2)

Max. speed: 12000 rpm

Max. torque: 14 Nm

Collet: ER25

Direction of rotation: ↻ ↻

Ratio: 1:2

Cooling: external (internal cooling available)

Accessories

Nut : Clamping wrench type E 25

Spindle: Hook wrench DIN 1810B 45-50

