

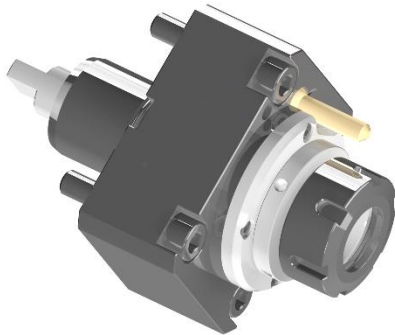

STRAIGHT LIVE TOOL HOLDER

MORI SEIKI
BMT 40 TURRET



RGX2-40/101-32/2-12K(MS)

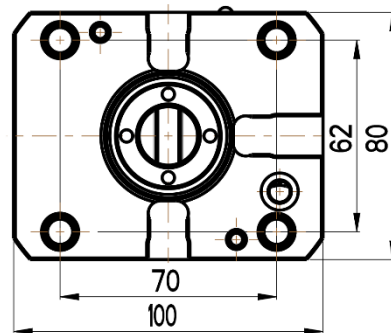
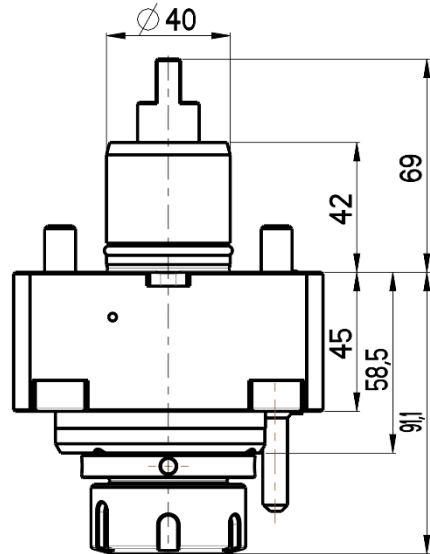

Max. speed: 12000 rpm

Max. torque: 50 Nm

Collet: ER32

Direction of rotation: 

Ratio: 1:1

Cooling: external & internal

Max. pressure: 20 bar

Accessories

Nut : Clamping wrench type E 32



Spindle: Hook wrench DIN 1810B 52-55

