

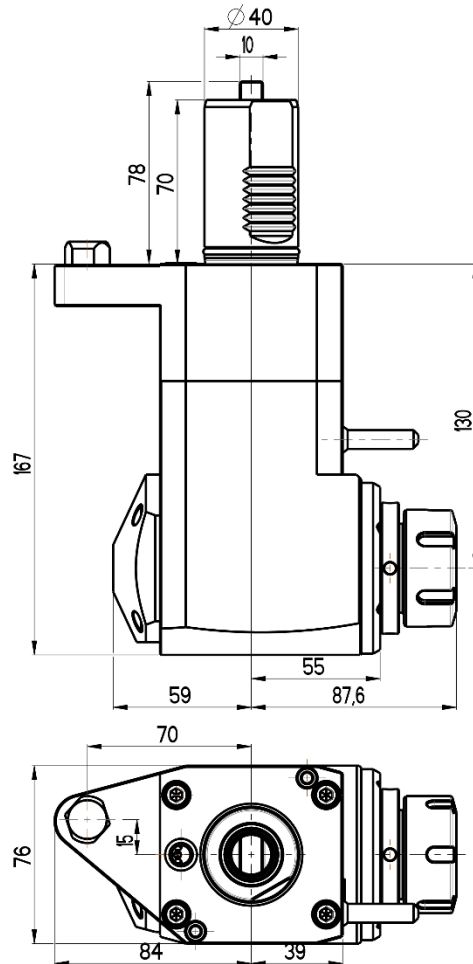

# ANGULAR LIVE TOOL HOLDER

## MAZAK QTN200/250

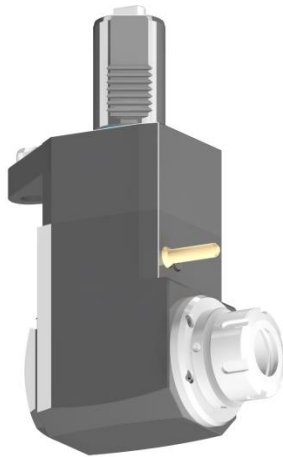

**RGX1-40/221-32/1.1-130MZ2**

**Max. speed:** 6000 rpm

**Max. torque:** 50 Nm

**Collet:** ER32

**Direction of rotation:**

**Ratio:** 1:1

**Cooling:** external (internal cooling available)

### Accessories

**Nut :** Clamping wrench type E 32

**Spindle:** Hook wrench DIN 1810B 52-55

