

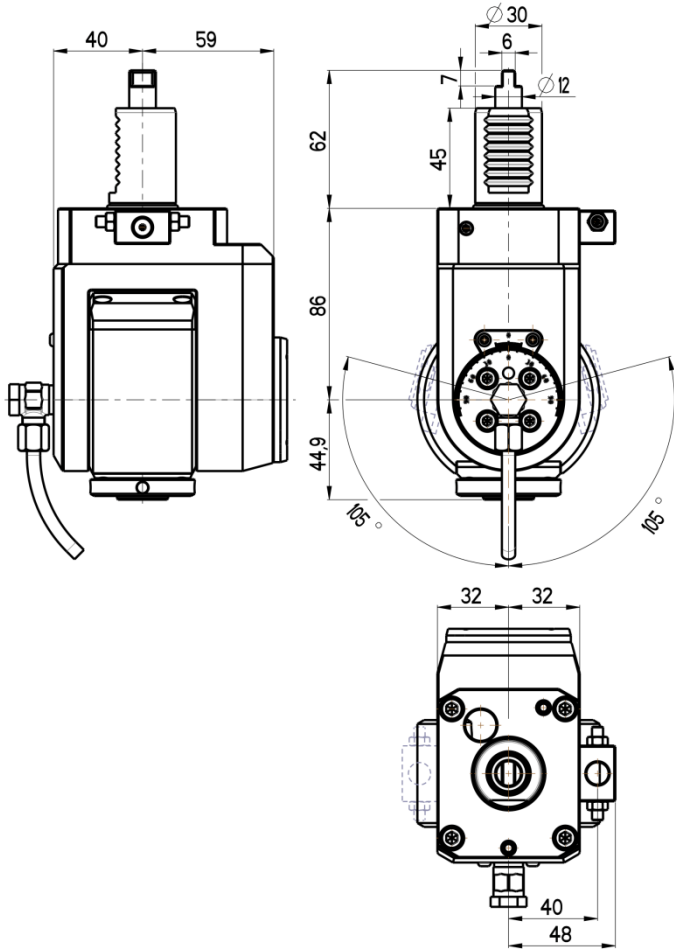

# VARIABLE ANGLE LIVE TOOL HOLDER

VDI 30 / DIN 1809

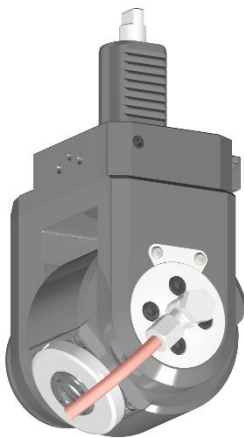

## RGX1-30/521-16/2.2

**Max. speed:** 6000 rpm

**Max. torque:** 16 Nm

**Collet:** ER16

**Direction of rotation:**

**Ratio:** 1:1

**Cooling:** external & internal

**Max. pressure:** 20 bar

### Accessories

**Nut:** Caliper pin wrench

**Spindle:** Spanner 28