

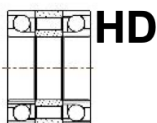

# STRAIGHT LIVE TOOL HOLDER

VDI 40 / OKUMA

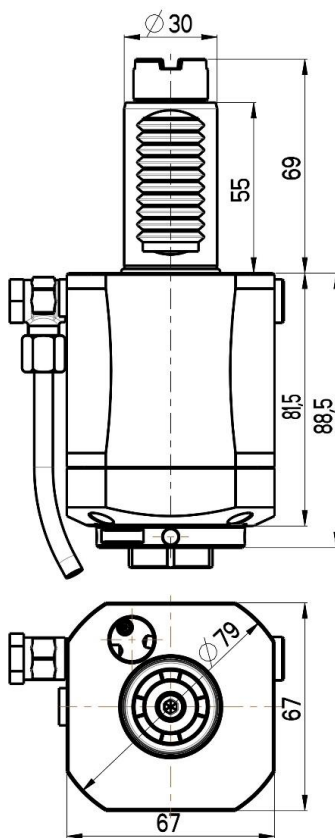

HD



ED

**RGX1-40/155-32/3HDJA**

**Max. speed: 6000 rpm**

**Max. torque: 28 Nm**

**Collet: ER232**

**Direction of rotation:**



**Ratio: 1:1**

**Cooling: external + internal max. pressure 80 bar**

## Accessories

**Nut :** Clamping wrench type E 27

**Spindle:** Hook wrench DIN 1810B 45-50

