

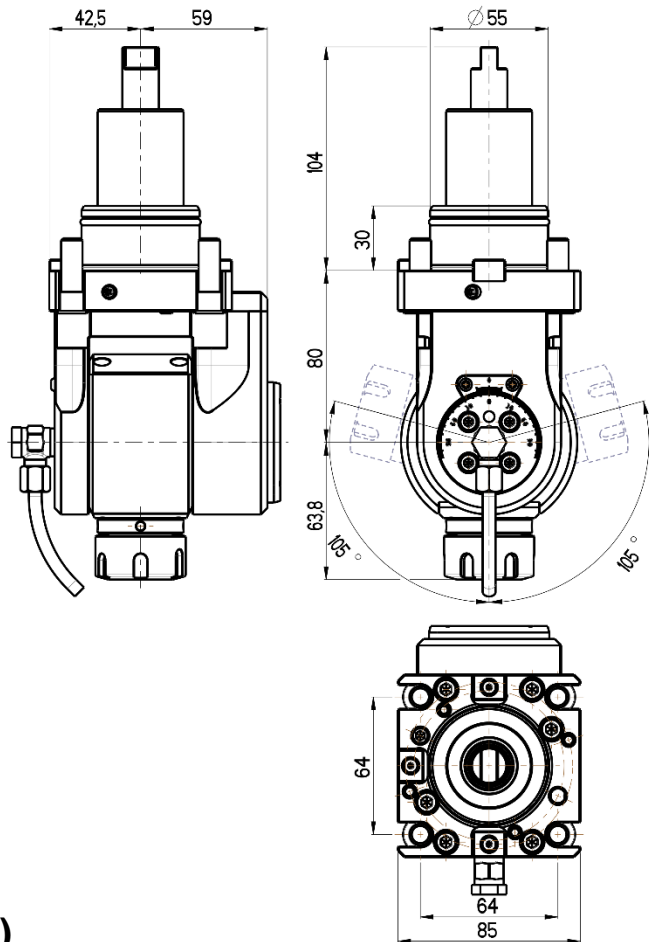

**VARIABLE ANGLE
LIVE TOOL HOLDER
DOOSAN, Victor. Hwacheon
BMT 55 TURRET**

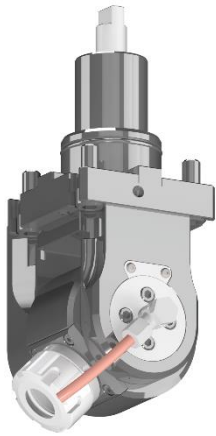

RGX2-55/501-25/1(DO)

Max. speed: 6000 rpm

Max. torque: 16 Nm

Collet: ER25

Direction of rotation:

Ratio: 1:1

Cooling: external (internal cooling available)

Accessories

Nut : Clamping wrench type E 25

Spindle: Hook wrench DIN 1810B 40-42

