

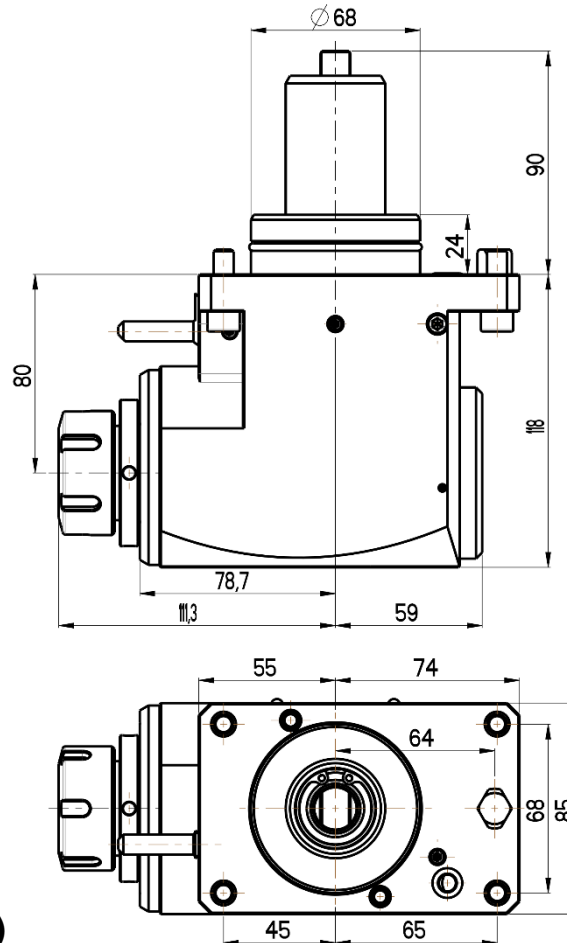

# ANGULAR LIVE TOOL HOLDER

MAZAK

BMT 68 TURRET

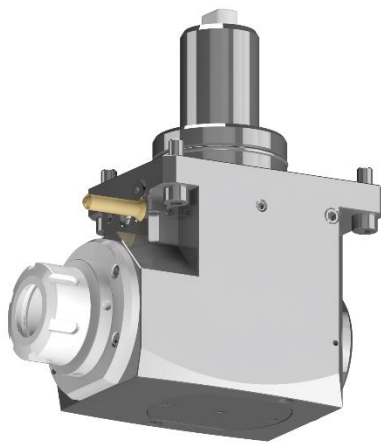

**RGX2-68/201-32/1.3-80(MZ)**

**Max. speed:** 6000 rpm

**Max. torque:** 70 Nm

**Collet:** ER32

**Direction of rotation:**

**Ratio:** 1:1

**Cooling:** external (internal cooling available)

### Accessories

**Nut :** Clamping wrench type E 32



**Spindle:** Hook wrench DIN 1810B 58-62

