

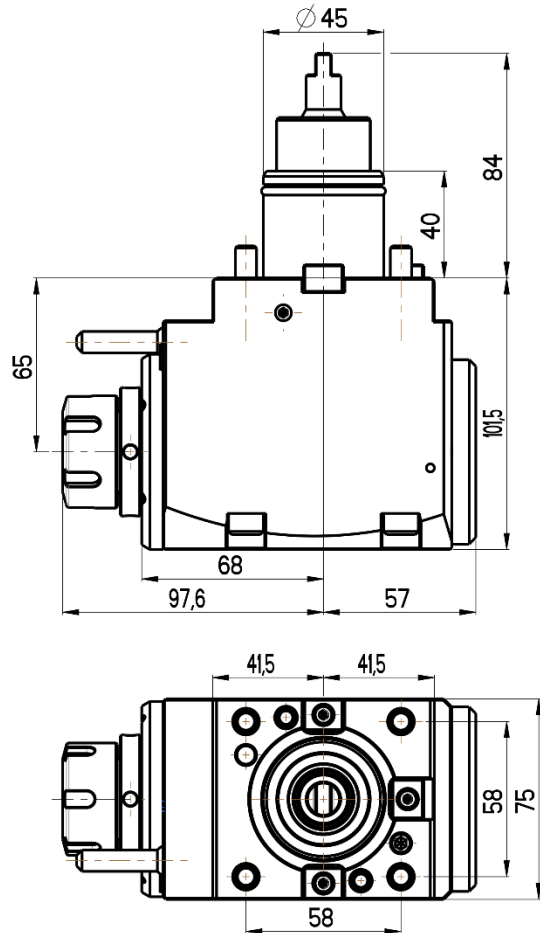

# ANGULAR LIVE TOOL HOLDER

DOOSAN, Hardinge

BMT 45 TURRET

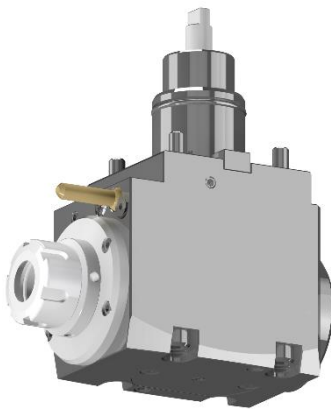

**RGX2-45/201-25/1.3-65(DO)**

**Max. speed:** 6000 rpm

**Max. torque:** 50 Nm

**Collet:** ER25

**Direction of rotation:** 

**Ratio:** 1:1

**Cooling:** external (internal cooling available)

### Accessories

**Nut :** Clamping wrench type E 25



**Spindle:** Hook wrench DIN 1810B 45-50

