

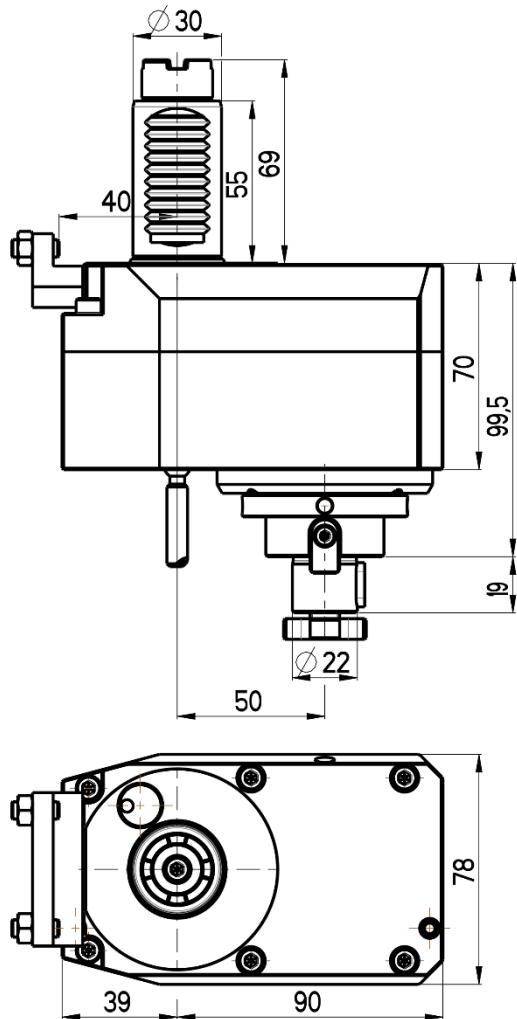

OFFSET STRAIGHT LIVE TOOL HOLDER VDI 30 / STEPPED



RGX1-30/353-22/1.1-50JA(1:2)

Max. speed: 12000 rpm

Max. torque: 14 Nm

Shell mill: $\varnothing 22$

Direction of rotation: 

Ratio: 1:2

Cooling: external (internal cooling available)

Accessories

Nut : Wrench DIN 6368 22

Spindle: Hook wrench DIN 1810B 52-55

