

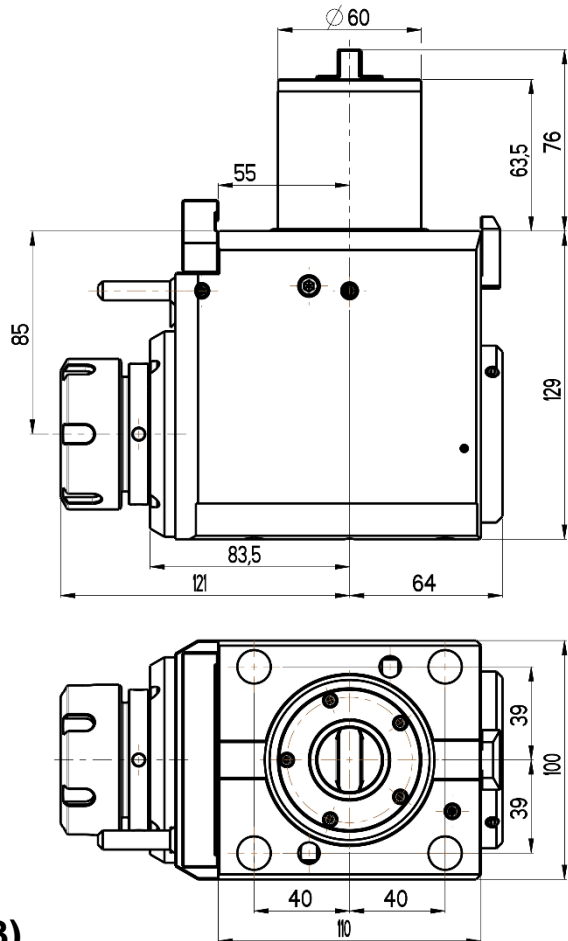

ANGULAR LIVE TOOL HOLDER

OKUMA TURRET
LB 4000 EX M

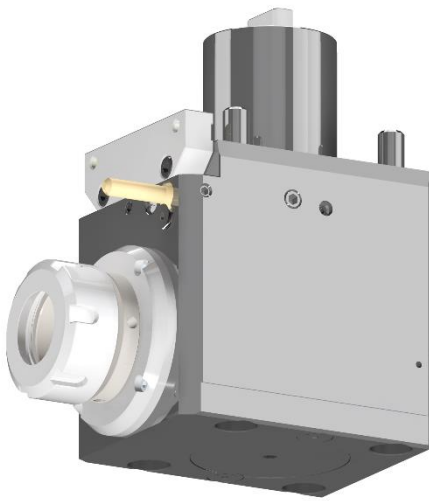

RGX2-60/201-40/1.3-85(JB)

Max. speed: 6000 rpm

Max. torque: 80 Nm

Collet: ER40

Direction of rotation:

Ratio: 1:1

Cooling: external

Accessories

Nut : Clamping wrench type E 40

Spindle: Hook wrench DIN 1810B 58-62

