

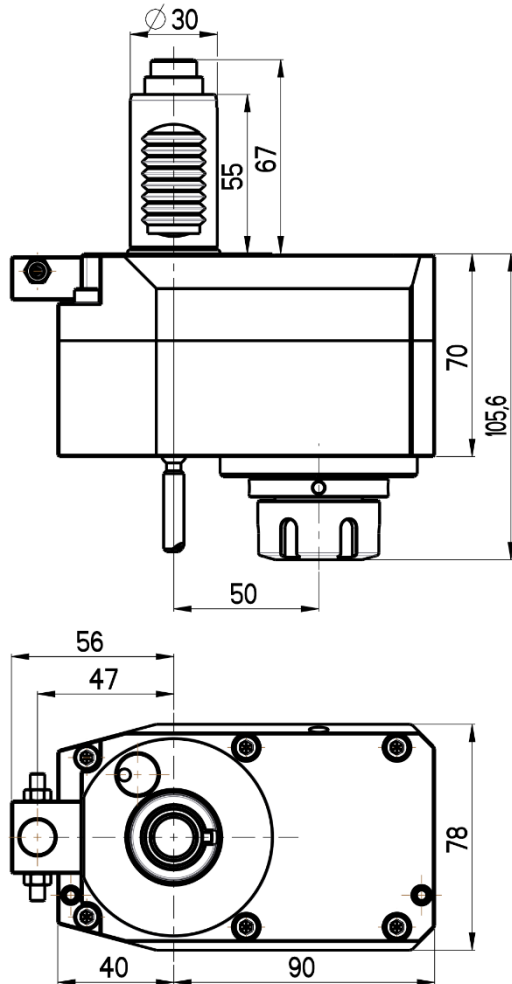

# OFFSET STRAIGHT LIVE TOOL HOLDER

VDI 30 / DIN 5480

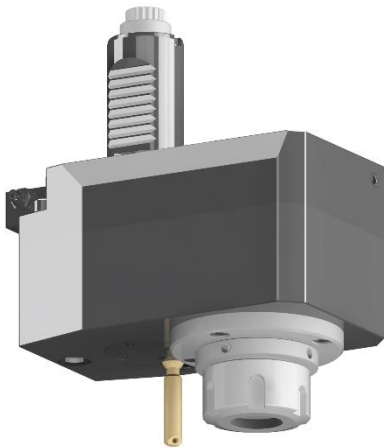

**RGX1-30/331-25/1.1-50(1:2)**

**Max. speed:** 12000 rpm

**Max. torque:** 14 Nm

**Collet:** ER25

**Direction of rotation:** ↻ ↻

**Ratio:** 1:2

**Cooling:** external (internal cooling available)

### Accessories

**Nut :** Clamping wrench type E 25

**Spindle:** Hook wrench DIN 1810B 45-50

